

# The Natural Air 180 MVHR system

Improved air quality with built-in flexibility

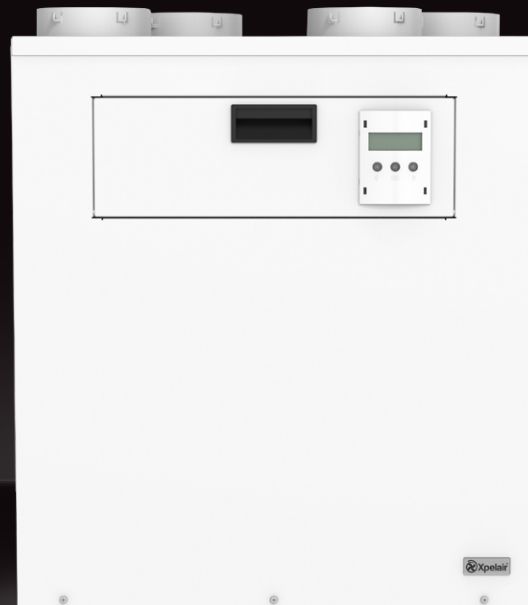

## Improving air quality for over 50 years

Xpelair – part of the Glen Dimplex Group – is one of the most recognised ventilation brands in the world. For over 50 years, we've been at the forefront of air-comfort technology. Our goal: improve the nation's health and well-being by ensuring the air we breathe is clean, fresh and healthy.

With today's increasingly stringent building regulations, it's reassuring to know you can count on Xpelair to keep you ahead of the game. Xpelair solutions are designed to give a comfortable, healthy and energy-efficient environment all year round. In addition, by removing humidity from wetroom areas, the build-up of condensation, damp and mould-growth can be eliminated. Our dedicated design team strives to deliver innovative ventilation solutions that not only comply with the latest regulations, but are leading-edge in their effectiveness and adaptability. The Natural Air 180 is no exception.



### Xpelair System Design Service

From initial design to installation and commissioning, we can guide your ventilation project from start to finish. Let us take the hassle out of your next project. To find out more, please contact [designs@redringxpelair.com](mailto:designs@redringxpelair.com)

## Taking MVHR to new territory

Mechanical Ventilation with Heat Recovery (MVHR) is nothing new. The concept is well proven. Pass fresh air from outside over warm, stale air extracted from inside and use the heat to raise the temperature of the incoming flow.

But the Natural Air 180 brings a fresh perspective in more ways than one. No other MVHR system gives you more built-in flexibility for customisation to meet non-standard situations. Coupled with its compact design and suitability for whole-house ventilation, the Natural Air 180 delivers classic MVHR benefits ideal for 2-3 bedroom houses and apartments.

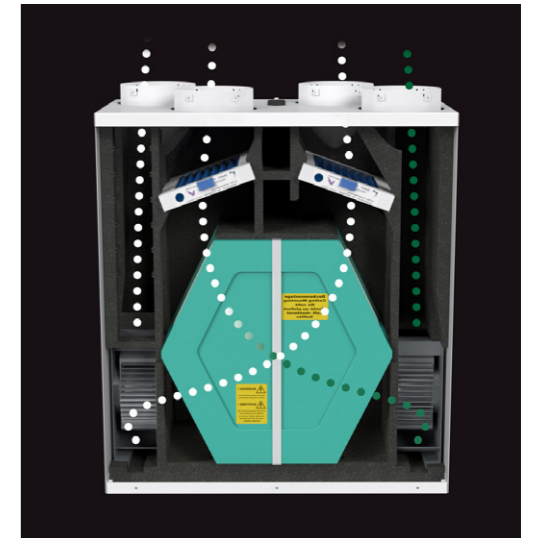

### MVHR in action

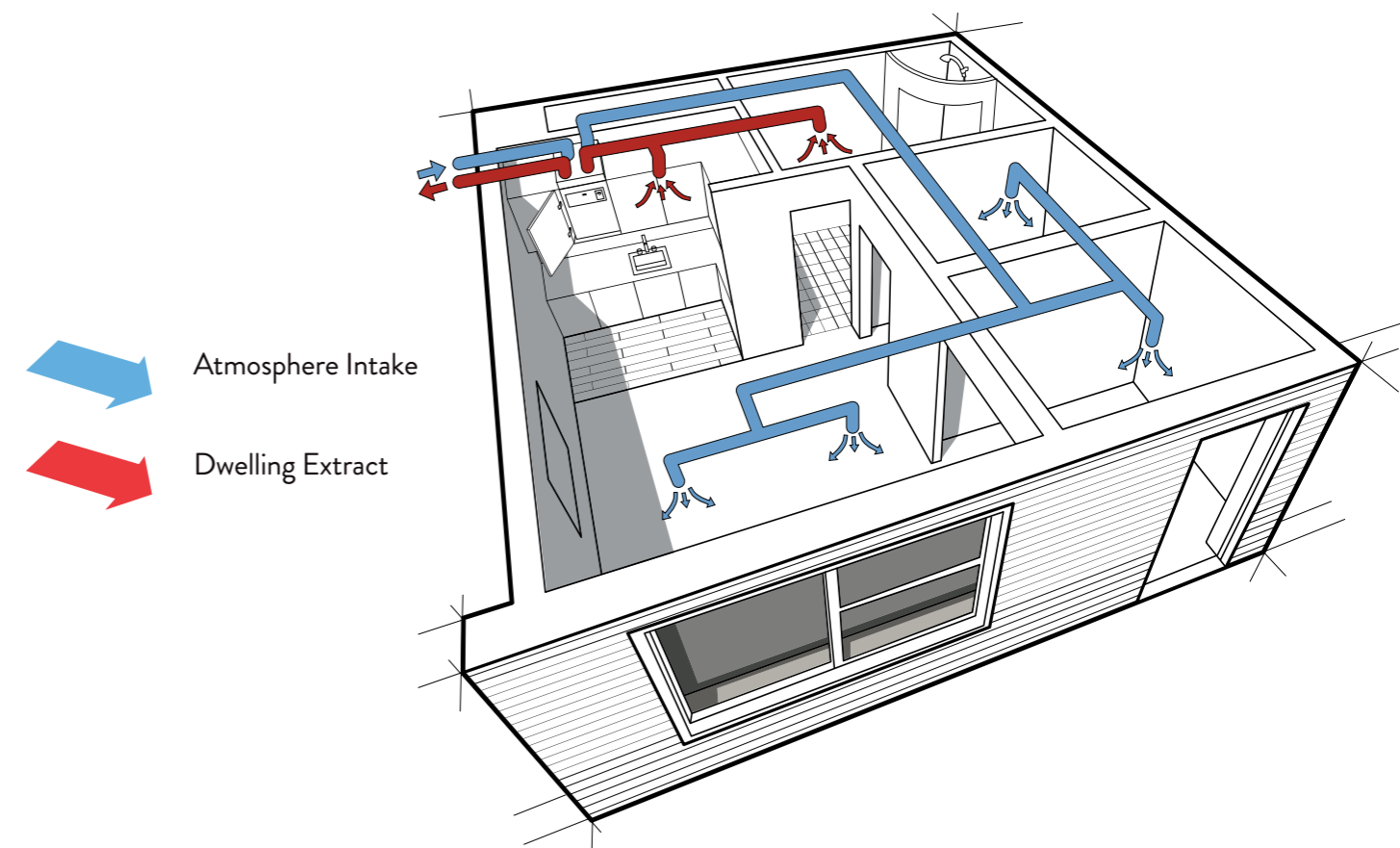

## The growing demand for improved air quality

By 2050, the Government wants to see carbon emissions down by 80%. Which means the trend towards improved air-tightness and thermal efficiency in new-builds is set to continue. But there's a flip side. Some homes are now so well-sealed, indoor air quality is suffering. On top of this, longer drying-out means prolonged higher humidity. This isn't just bad for buildings, it's bad for our health.

The economic downturn has made things even worse. With budgets squeezed, housebuilders and specifiers naturally opt for simple extractor fans rather than a balanced ventilation system. The result? Airborne pollutant levels are on the rise – and are likely to be at their highest in newly built and newly renovated homes.

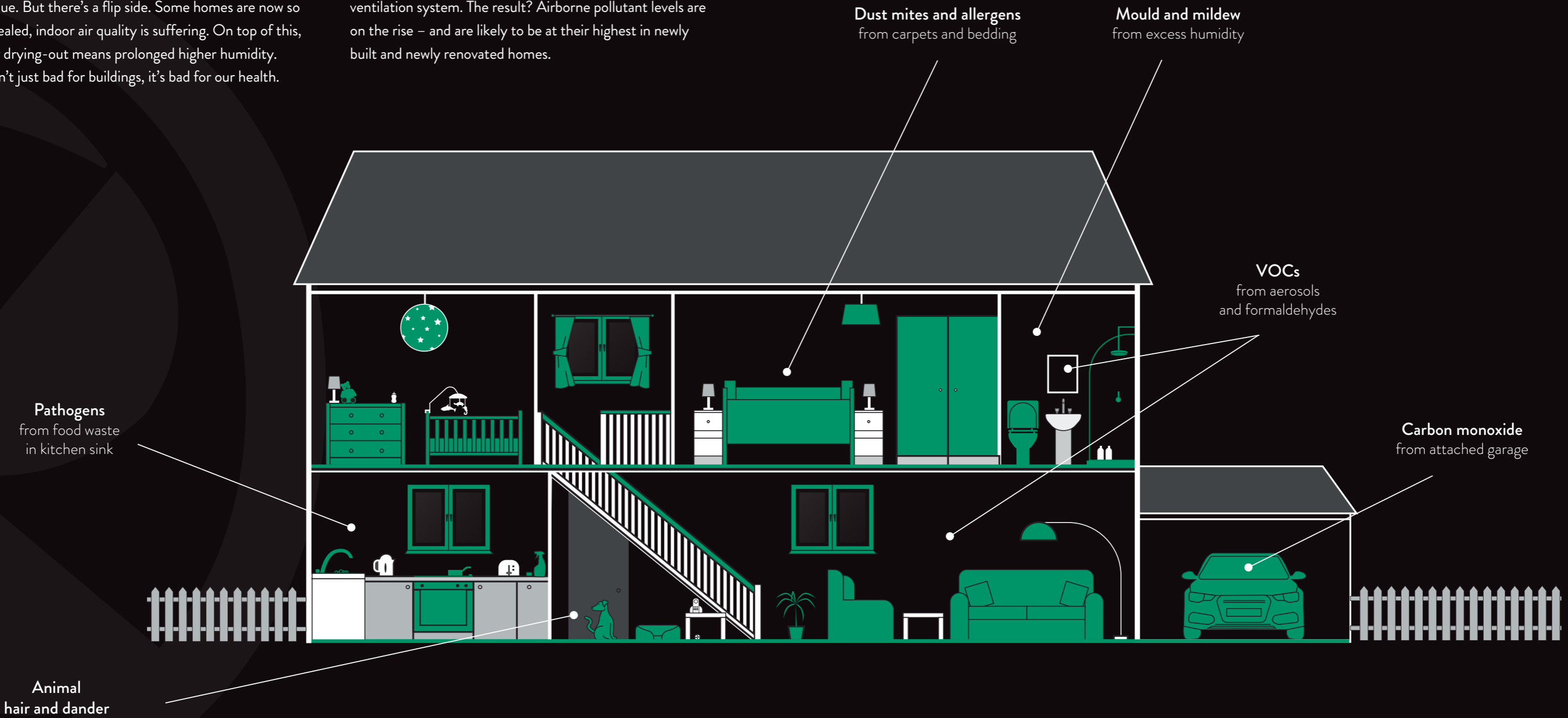

### Why things MUST change

Further regulation is planned to step up energy efficiency even more.

Some 22 million existing homes will need work to meet future carbon emission obligations.

30% of all emissions are from domestic buildings.

Forecasts suggest an 80% increase in asthma unless indoor air quality is improved.

Health-threatening pollutants are forecast to exceed WHO safety guidelines by up to 30% for NO<sub>2</sub> and up to 60% for TVOC (Toxic Volatile Organic Compounds).

## Meet regulations with ease

The Building Regulations in the UK sets out some stringent standards. In England and Wales, you'll find these in Approved Document Part F, Ventilation. You can download this from [www.planningportal.gov.uk](http://www.planningportal.gov.uk)

The good news is compliance is easy. Current Part F regulations single out MVHR units, such as the Natural Air 180, as the most sophisticated ventilation systems available. You can see from the table below how readily MVHR systems meet the minimum required whole-building ventilation rates.



## Part F

The performance rates for each of the 'System' approaches set out in Part F are the minimum requirements needed to ensure that adequate air quality is provided for people indoors.

### System 1

Background Ventilation and Intermittent Extract Fans

### System 2

Passive Stack Ventilation

### System 3

Continuous Mechanical Extract Ventilation

### System 4

Continuous Mechanical Supply and Extract With Heat Recovery

Regulations are constantly being reviewed and revised, with the aim to improve the building standards in the future. These revisions have paved the way towards ventilation becoming a controlled service, focusing on energy efficiency and correct installation to ensure what is specified is fitted correctly and works for the end-user.

The occupant's health could be at risk if these ventilation rates are compromised. The following systems are outlined which satisfy the performance standard:

As regulations become more stringent, our homes are getting warmer, tighter and require more adequate ventilation.

This has led to an increase in the demand for more sophisticated ventilation products such as MVHR – System 4.

## System 4: MVHR

Mechanical Ventilation with Heat recovery (MVHR) is covered under System 4 of the Building Regulations, Part F. Heat recovery ventilation provides fresh, filtered air, energy efficiency and a comfortable all year round climate. Stale, moist air is extracted out of the wet rooms of a home.

These include the kitchen, bathrooms, utility and en-suite rooms. MVHR systems should always provide the minimum whole building ventilation rate, which can be calculated using the following steps:

**Step 1:** Determine the whole dwelling ventilation rate in Table 5.1b from Approved Document Part F

Number of bedrooms in dwelling	1	2	3	4	5
Whole building ventilation rate <sup>1</sup> 2(l/s)	13	17	21	25	29

1. In addition, the minimum ventilation rate should not be less than 0.3l/s per m<sup>2</sup> internal floor area (this includes each floor, e.g. for a two-storey building, add the ground and first floor areas).
2. This is based on two occupants in the main bedroom and a single occupant in all other bedrooms. This should be used as the default value. If a greater level of occupancy is expected, then add 4l/s per occupant.

**Step 2:** Calculate the whole building extract rate from Table 5.1a in Approved Document Part F

by taking the 'minimum high rate' and multiplying this by the number of ventilated rooms in the dwelling eg: if an individual MVHR system is fitted in the kitchen, bathroom and en-suite, the total minimum high rate would be 13l/s plus 8l/s for the bathroom and 8l/s for the en-suite = 29l/s

Room	Minimum Intermittent Extract Rate	Continuous Extract	
		Minimum High Rate	Minimum Low Rate
Kitchen	30l/s (adjacent to hob) or 60l/s (elsewhere)	13l/s	Total extract rate must be at least the whole building ventilation rate in table 1.1b
Utility Room	30l/s	8l/s	
Bathroom	15l/s	8l/s	
Sanitary Accommodation	6l/s		

**Step 3:** The required extract rates are as follows:

The minimum whole-dwelling extract ventilation rates (ie: the boost rate) should be at least the greater of Step 1 and Step 2. The minimum whole dwelling extract ventilation rate should be at least the whole dwelling rate as found in Step 1.

## Get set for better SAP ratings

SAP may not always be your highest priority, but here again the Natural Air 180 comes into its own. How? Because SAP (Government Standard Assessment Procedure for Energy Rating of Dwellings) looks at how

well a home meets Part L of the Building Regulations. Since ventilation rates and the efficiency of the ventilation system help determine a property's SAP energy rating, a low Specific Fan Power (SFP) is key.

## Fast-track your Passivhaus path



Back in 1990, the ground-breaking pilot Passivhaus project set unprecedented standards of energy efficiency in residential building design. This forward-thinking model for zero carbon emissions for new homes is now the world's most widely adopted voluntary energy performance standard.

What does it take for a new home to make the Passivhaus grade? Two things, above all.

One: build exceptionally air-tight, thermally efficient homes.

Two: manage indoor air quality with cost-effective, mechanical, balanced ventilation.

The Passivhaus pilot used MVHR systems. Even then the designers saw this ingenious ventilation methodology as the optimal solution. Advances in MVHR system design followed, bringing the ideal closer to a realistic norm. Now, with the arrival of the Natural Air 180, you can pioneer Passivhaus standards in all kinds of builds and environments.



## Why the Xpelair Natural Air 180 is your go-to MVHR solution



### Constant Volume for life.

The Natural Air 180 uses Intelligent Adaptiflow Sensing to deliver constant volume performance. The motor is constantly assessing the performance of the impeller and, when there is a consistent change in airflow, brought about by reduced efficiency or by a strong wind applying back pressure, the motor adjusts the speed of the fan to maintain a constant volume of extracted air.



### Clever humidity control.

Unique, active humidistat reacts in real-time to gradual increases in humidity – perfect for even the smallest wet room. Flow rate is boosted only as needed, minimising energy costs and further reducing acoustic output. No more nuisance tripping as night-time temperatures drop. You set the humidity threshold to suit conditions – factory setting for boost is a 4% humidity rise in 5 minutes.



### Hassle-free maintenance.

Fast, simple access to fans, filters and heat exchanger. Slide out filters to replace. Lift out heat exchanger and rinse clean in warm water. Sealed, maintenance-free, ball bearing EC motor.



### Peace of mind.

As a measure of our confidence, the Natural Air 180 comes with a two-year warranty.



### Datalogger.

Designed to help landlords and local authorities reduce damage to their properties through condensation and mould, the Natural Air 180 has an integral datalogger, recording its daily use. This provides instant information, showing whether the unit has been in use or a tenant has switched it off. This information is easy to access and can be taken directly from the unit whenever the owner visits the property.



### Ultra-efficient heat exchange.

Heat exchanger recovers both sensible and latent energy from exhaust air and transfers this to incoming flow, minimising waste.



### Cool recovery comes as standard.

Dual condensate drains capture additional moisture generated in climate controlled buildings.



### Constant regulation.

A temperature sensor inside each duct monitors exhaust and supply air and activates summer bypass, winter defrost and optional pre-heater for year-round comfort.



### Fans you can forget about.

Purpose-designed for trouble-free continuous operation. Rigid powder-coated steel housing prevents corrosion and prolongs life. Forward-curved impellers are specifically designed for optimal efficiency.



### Simple installation.

Quick and easy on the job, thanks to Xpelair's So Simple installation – see page 13.



### Silent nights and days.

Sound-absorbing EPP material dampens mechanical noise. Direct air flow path minimises internal pressure drop resulting in whisper-quiet operation.



### Low Specific Fan Power.

Smooth pressure drop thanks to the energy efficient heat exchanger, G4 filter and unit-specific fan configuration.



### Worry-free filter.

The control panel tells users when the filter needs changing. It's set for a 2 – 12-month cycle, at run-time not lapsed-time, so it's unaffected if the unit is switched off. Making it cheaper to replace than other filters on the market, yet just as effective.



### Cool summers.

Summer bypass mechanism kicks in to circumvent heat recovery when indoor temperature exceeds outside temperature and preset comfort level, day or night. Yet, as with other Xpelair MVHR systems, summer bypass doesn't mean filter bypass. Incoming air still passes through the unit's filter.



### Additional winter protection.

To further prevent freezing, a heater installed in the dwelling supply duct pre-heats the incoming fresh air. The heater is available as an accessory to be used with the PH unit.



### Freeze-free winters.

Integrated defrost sensor guards against moisture turning to ice in the heat recovery cell. Any time exhaust air temperature exiting the cell falls below +3 °C, the supply fan goes into standby mode and only restarts when the reading approaches +8 °C.



### Safe in the event of fire.

Automatic shutdown should fire alarm go off. Manual restart when alarm stops.



### Control panel.

Although the Natural Air 180 is designed to work for continuous trouble-free operation, it can also be tailored to individual needs using the control panel. Energy can be conserved by switching to night-time mode and holiday mode, which employs trickle ventilation overnight, during holidays or when the property is vacant. The system can also be purged whenever required by using boost switching. Summer bypass control and the active humidity setting enable the unit to adjust to warmer temperatures or rising humidity. The system also performs diagnostics and displays advisory codes to help technicians maintain the unit.

## Natural Air 180 add-ons and integrations

No loft space? No problem. Need NOX filtering? Just ask. Humidity sensor? All this and more is just an add-on away.

**Customise your configuration.** All units are compatible with the External Sensor Board (93324AA) which allows for additional control options.









**NOX filtration for cleaner, safer air (via external filter box).** Potential lifesaver in areas with unsafe levels of sulphur dioxide, nitrogen dioxide or VOCs.

**Single humidity sensors.** Great when you need to control local air quality of individual wet rooms. Requires External Sensor Board.

**PIR sensor.** This movement-activated PIR sensor brings yet another efficiency enhancement to wet rooms. Requires External Sensor Board.

**Air quality sensor.** This odour-activated sensor provides fully automatic ventilation when contaminants such as smoke and smells are detected. Requires External Sensor Board.

## Ancillaries

<p>Natural Air Humidity Sensor</p>  <p>93320AA</p>	<p>AQS Controller 220-240V 50/60Hz</p>  <p>92097AW</p>	<p>Natural Air PIR Sensor</p>  <p>93321AA</p>
<p>Natural Air CO2 Sensor</p>  <p>93330AA</p>	<p>Natural Air Remote Operation Kit</p>  <p>93329AA</p>	<p>Natural Air External Sensor Board</p>  <p>93324AA</p>
<p>MVIC Multi Ventmiser Input Controller</p>  <p>92630AA</p>	<p>Natural Air Quality Module – Carbon</p>  <p>93323AA</p>	

## Ducting design matters

Heat recovery is a system comprising two components – the heat exchange unit and the ducting. The design and quality of both is equally important in achieving assured installed performance. Ducting affects:

Short and long-term indoor air quality	Speed and ease of installation
System efficiency and airflow rates	Noise levels

With traditional ducting systems, installers need to make multiple connections manually, each of which has an impact on system integrity. This calls for on-site sealing, adding to installation time, and exposing every ducting connection point to the risk of air leakage. Here at Xpelair, we are determined to offer ranges of ducting that both comply with building regulations and are straightforward for the installer. Our main MVHR ducting ranges:

### Thermal ducting

Ducting in MVHR systems carry warm air through them. When these ducts pass through unheated spaces, such as a loft, if the ductwork does not have sufficient thermal insulation then condensation can form on and in the ductwork and cause water damage to a property.

Xpelair's range of thermal duct is specifically designed to comply with 2010 Building Regulations to significantly improve thermal conductivity and thermal resistance of ventilation ducting used in domestic properties.

Ducting should be insulated where it passes through unheated areas and voids (e.g. loft spaces) with equivalent of at least 25mm of a material having a thermal conductivity of  $\leq 0.04W/(m.K)$  to reduce the possibility of condensation forming. Where a duct extends above roof level, the section above the roof should be insulated or a condensate trap should be fitted just below roof level. Benefits are:

Fully compliant with Building Regulations	Lightweight material – one person install
Improved thermal efficiency	Simple quick-fit components
Clever clamping mechanism – no requirement for sealant and tape	Significantly reduces time on site

### Semi-rigid ducting

Semi-rigid ducting is essentially the mid-point between rigid and flexible ducting. Semi-rigid duct is a perfect choice for MVHR heat recovery system installations as it provides huge performance benefits whilst dramatically reducing installation time and installation risk on-site.

An MVHR heat recovery system requires a considerable amount of duct and air leakage can occur within the duct network at the point where components are joined. Xpelair semi-rigid ducting requires no joins.

It combines the performance benefits of rigid duct and the installation benefits of flexible duct	The material and shape of semi-rigid ducting means it can take higher external load pressures, meaning less damage on site during installation
Semi-Rigid Duct is classified the same as rigid duct in SAP	Lower noise levels due to fewer bends in the system

## Easy maintenance

To access the fans and heat exchanger for maintenance, simply remove the front panel.

## So Simple installation

The Natural Air 180 has been designed for easy installation and hassle-free handling. And, as it comes in two sections rather than one, it's a lot more portable than all-in-one units. The metal case is 9.5kg and the EPP is 10kg.

Site MVHR unit in cupboard or loft space.

Use rigid aluminium, PVC or semi-rigid plastic ducting.

Every system comes with full installation and user manuals.

### Step by step.



#### Step 1

Remove the metal jacket from the unit. There are 8 screws in total – 3 for the front door, 5 for the lid.



#### Step 2

Mount the rear chassis on the wall using 4 screws (4 mounting points).



#### Step 3

Refit the EPP body into the metal jacket. Remove the heat exchanger cube to install the required drain connections.



#### Step 4

Refit the lid and door.

## Learn more about meeting ventilation standards

With Passivhaus principles very much in line with Xpelair's own, who better to get your training from? We offer two levels of learning:



### BPEC two-day courses

These courses conform to the new Summit Skills syllabus for ventilation and are certified by the independent training organisation BPEC. Through both theoretical and practical training, you'll learn about the main types of domestic ventilation systems and how to install them safely and efficiently, then test them afterwards. On completion, you'll receive a certificate of competence valid for five years.



### CPD one-hour seminar

Specifying Heat Recovery Ventilation in the Design of Domestic High Code Level and Passivhaus Properties. This industry-approved CPD seminar covers the principles of heat recovery, meeting Passivhaus standards and best practice for domestic heat recovery – ideal for those seeking to gain a basic understanding of the MVHR opportunity within a limited time frame.

For more details, please contact [designs@redringxpelair.com](mailto:designs@redringxpelair.com)

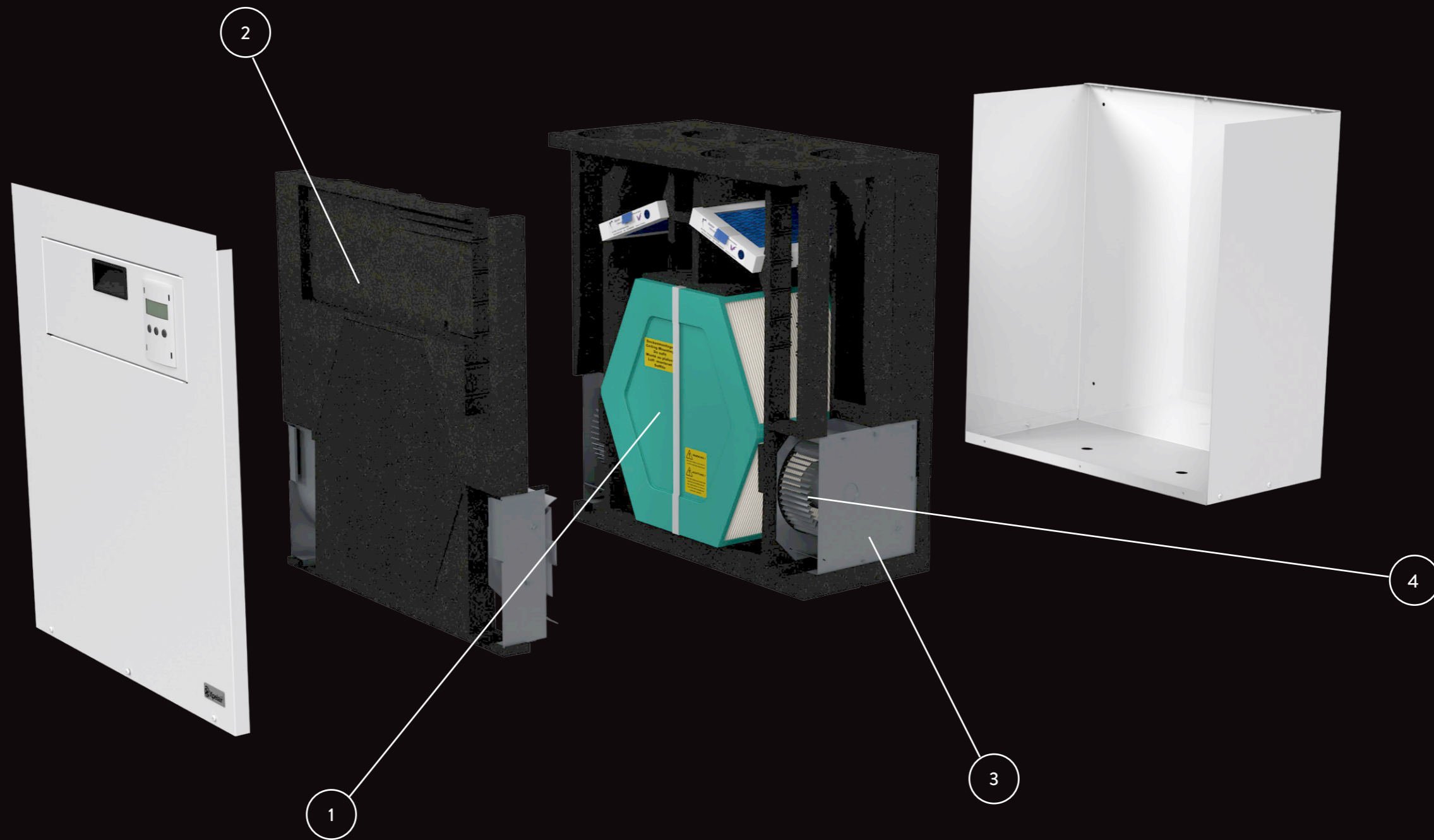

## Ghost™ Air Movement Technology

The Natural Air 180 might be a powerhouse of air filtration, but it's so quiet you'd never know it. That's because our innovative Ghost™ Air Movement Technology uses brushless EC motors and intelligent design to minimise mechanical noise and create a direct air flow path.

## A look inside



Direct air flow path  
reduces turbulence.



Sound-absorbing  
EPP material suppresses  
mechanical noise.



Brushless ball-bearing  
motors for  
ultra-quiet running.



Specifically designed  
fans operate at  
optimal efficiency.



## Natural Air 180 Data

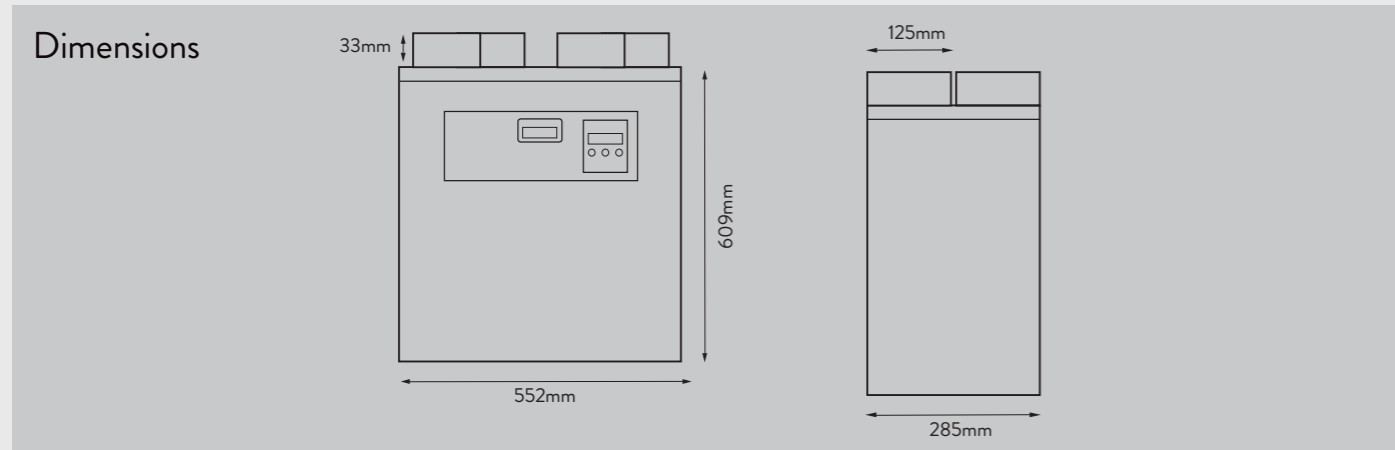

Natural Air 180 Data Table

	Xpelair Natural Air 180	Xpelair Natural Air 180 PH
Reference number	93256AW	93319AW
Motor Type	EC	EC
Speeds	trickle/boost/purge	trickle/boost/purge
Maximum Extract Performance (FID, m <sup>3</sup> /h)	230	230
Maximum Extract Performance (m <sup>3</sup> /h @250Pa)	218	218
Maximum Extract Performance (FID, l/s)	64	64
Maximum Extract Performance (l/s @250Pa)	60	60
Maximum Fan Power (W)	154	154
Spigot Diameter (mm)	125	125
Weight (kg)	19.5	19.8
UK Guarantee (years)	2	2

PH unit has heater connection sockets and the required power board.  
Natural Air 180 Plus (93333AW) includes integrated external sensor board.

## Efficiency

Kitchen	Thermal Efficiency (%)	SAP Appendix Q Data	
		Specific Fan Power 2005 Standard (W/l/s)	Specific Fan Power 2012 Standard (W/l/s)
+1 Additional Wet Room	89	0.64	0.68
+2 Additional Wet Room	88	0.66	0.83
+3 Additional Wet Room	86	0.76	1.04

## Airflow Curves

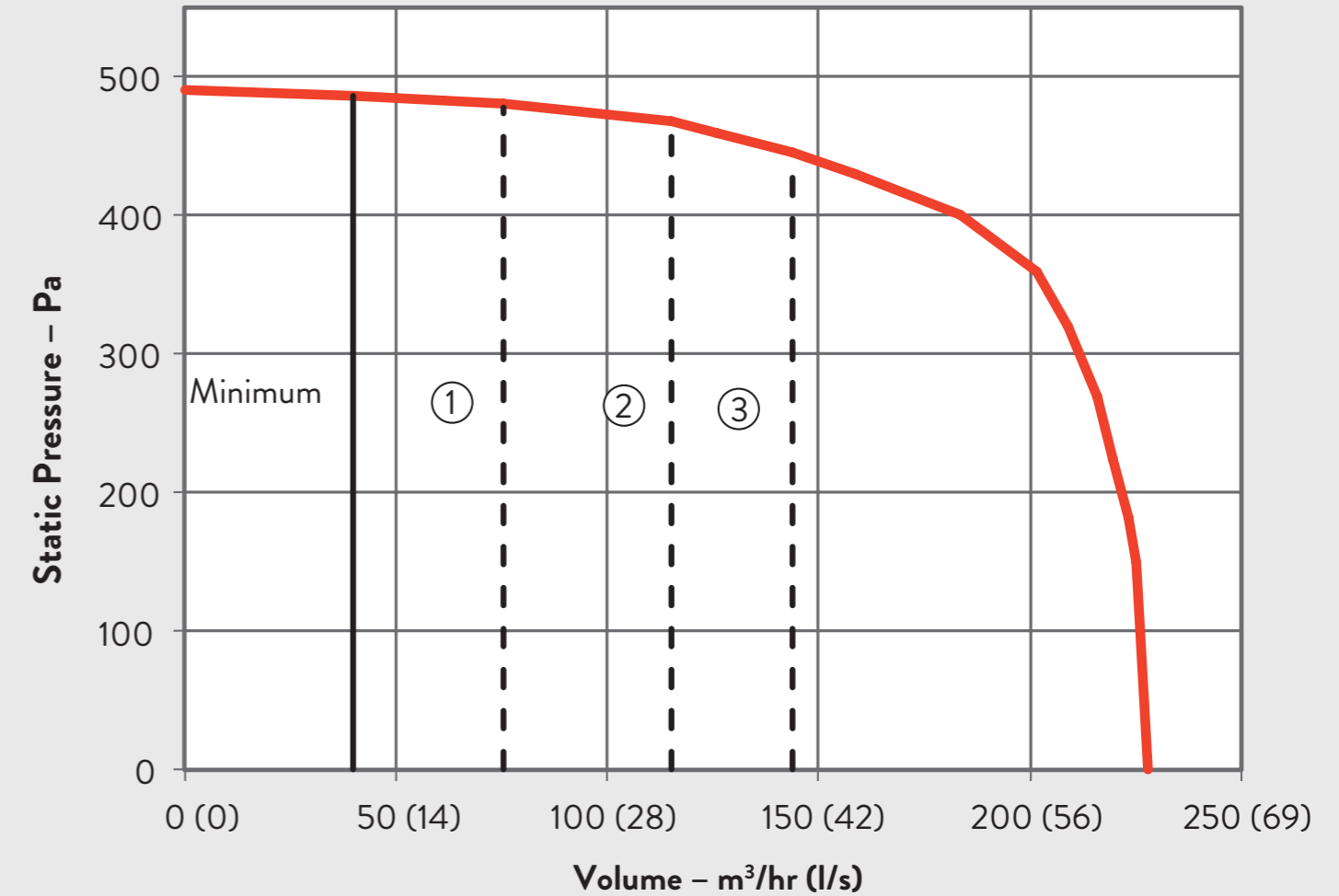

## Acoustic Data

Speed	Test Mode	Octave Band (Hz) Sound Power Levels, dB							SPL(dB(A)) at Unit	SPL(dB(A)) @ 3m
		100	250	500	1k	2k	4k	8k		
1	Unit	27.9	33.8	32.7	43.4	27.9	22.1	14.9	44.4	24.4
	Supply	53.2	54.1	49.7	56.1	42.6	33.4	21.1	59.9	39.9
	Extract	34.9	43.5	38.4	37.3	26	18.8	15.4	45.8	25.8
2	Unit	33	38.5	37.9	45.6	34.6	30.4	16.6	47.4	27.4
	Supply	59.8	57.4	54.5	62.7	50.4	41.9	30.7	65.8	45.8
	Extract	40.5	48.6	43.4	47.9	32.1	20.8	16.3	52.3	32.3
3	Unit	35	42.1	42.3	52.9	46.5	36.3	21.1	54.5	34.5
	Supply	63.1	61.5	59	63	70.1	47.4	36.8	72.2	52.2
	Extract	43	52.6	48.2	47.1	39.7	25.1	17.9	55.2	35.2

\*Independently tested at Building Research Establishment – April 2017.

## Other Heat Recovery Solutions

### Xcell Stratum S120Q, S155QVI & S275QVI

Compact, lightweight, low-profile horizontal heat recovery unit

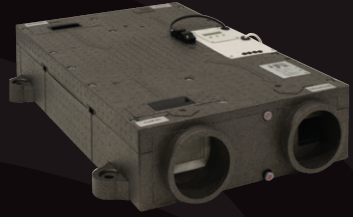

Xcell Stratum heat recovery units are compact, low profile and extremely installer-friendly, being much lighter to handle than metal cased units. They incorporate a high efficiency heat recovery counterflow cell for heat recovery of up to 90%, and feature high efficiency F5 G4 filters and can be both ceiling or loft mounted. The B1 rated EPP structural material has a high U value, so no cold bridging and features integral fixing points for simple loft or ceiling mounting. Available in three variable speed performance models with winter defrost, summer bypass and multiple control feature options.



### Muro XHRM

Through-the-wall single room dMEV heat recovery ventilator



Muro is an efficient through-the-wall heat recovery ventilation unit for single room and dMEV system applications in both residential and commercial build sectors. Muro units incorporate an 80% efficient counterflow heat exchanger which minimises heat loss, as stale air is exhausted, to improve room air quality. The quiet-running, low-energy DC motors enable the unit to be installed in bedrooms, which extends application to include commercial hotel and healthcare installations. The Muro also features an integral display for fan speed selection and filter/fault function, along with a removable front fascia for easy access to filters.



Request details of our Passivhaus variant.

## Setting air flow

The airflow is determined by the number of wet rooms the unit is serving. This can be set on the control panel. Once set, the unit will monitor impeller performance and, using Intelligent Adaptiflow Sensing, will always ensure the correct volume of air is extracted.

## Electrical specification

Wiring must comply with IET regulations.

1) Separately supplied with its own circuit from the consumer unit

OR

2) Fused spur from existing ring main.

Fuse protection : 6 Amp for NA180. 13 Amp for NA180PH.

## Consultant's specification – NA180

The unit shall be manufactured with an EPP construction, with powder-coated steel outer casing.

The unit shall have a high efficiency composite plastic counterflow heat exchanger, supply and extract filters, automatic summer bypass, integral minimum and maximum infinitely variable speed controls with fascia mounted failure indication. The unit shall have low energy, high efficiency EC fan/motor assemblies with sealed for life bearings. The impellers shall be high efficiency forward curved centrifugal type.

The motors shall be low energy EC with constant volume functionality.

The unit shall have the facility to commission the supply and extract fans independently on minimum speed (continuous background ventilation), and boost speed, via inbuilt minimum and maximum speed adjustment.

The unit shall have heat exchanger cell with a thermal efficiency of up to 92% when tested to EN 308. This shall be protected by G4 grade synthetic filters on supply and extract. Complete with a condensate drip tray and drain connection.

The unit shall be constructed with a removable door allowing full maintenance access. The removable door shall provide access to the following:

- Supply or extract fan
- Supply or extract filter
- Heat exchanger
- Access to the electrical connections

Access shall be provided for wiring termination and setup/commissioning. The user interface therein shall be removable for remote mounting if required.

Units shall be as manufactured by Redring Xpelair Group.

**NA180PH consultant's specification available upon request.**

#### UK Sales

Sales Hotline: 0844 372 7750

Sales Fax: 0844 372 7760

Sales Email: [rxsalesoffice@redringxpelair.com](mailto:rxsalesoffice@redringxpelair.com)

#### International Sales

Sales Hotline: +44 (0) 1733 456789

Sales Fax: +44 (0) 1733 456727

Sales Email: [int.sales@redringxpelair.com](mailto:int.sales@redringxpelair.com)

#### Technical Services

Service Hotline: 0844 372 7766

Service Fax: 0844 372 7767

Service Email: [technical.services@redringxpelair.com](mailto:technical.services@redringxpelair.com)



Newcombe House, Newcombe Way  
Orton Southgate, Peterborough  
United Kingdom, PE2 6SE

t 0844 372 7761  
f 0844 372 7762  
[www.xpelair.co.uk](http://www.xpelair.co.uk)

5 Charlestown Avenue,  
Charlestown Industrial Estate  
Craigavon, Co. Armagh, BT63 5ZF

t (028) 38 337317  
e [sales@glendimplexni.co.uk](mailto:sales@glendimplexni.co.uk)

Improving population health and well-being with innovative and energy efficient indoor air quality and air comfort solutions.

Xpelair is a registered trademark of Redring Xpelair Group Ltd (RXG). RXG reserves the right to alter product specification or appearance without prior notice. All finishes in this brochure are as accurate as printing processes allow.

All rights reserved.

[www.xpelair.co.uk](http://www.xpelair.co.uk)



[/xpelair](https://www.facebook.com/xpelair)



[@\\_xpelair\\_](https://twitter.com/_xpelair_)

